

## Glassforce 190 Door Rails

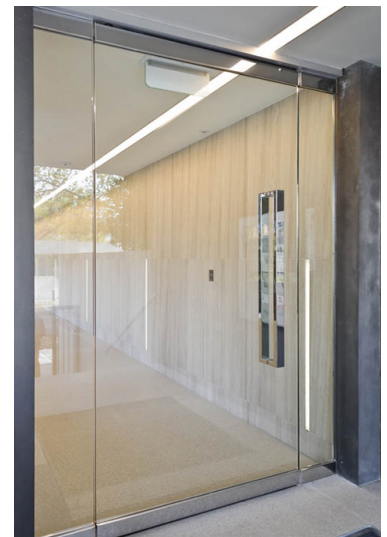

### Product Features

- Full width aluminium Door Rails are an alternative option to patch fittings and for use with oversize doors.
- The Rails are *clamped* onto the glass edge which means no holes or cutouts are required.
- A main feature of the Bottom Rail is to act as a 'kick plate' to lessen the chance of glass breakage.
- They can be used in combination with Top Patch Fittings and in Sliding Door installations.
- Compatible with most floor springs & floor pivots (pivot insert within rail).
- Available in Satin Anodised Aluminium or selected Powdercoat colour.
- Suitable for 10, 12 and 15mm glass, please specify glass thickness when ordering.
- Can be supplied with or without optional Brush Seal.



# Glassforce 190 Door Rails

## Top & Bottom Non-Locking Rail

Product Code	Description	Finish
DR1SA	Door Rail Top, Non-locking <800mm	SA
DR2SA	Door Rail Top, Non-locking 800-899mm	SA
DR3SA	Door Rail Top, Non-locking 900-1000mm	SA
DR7SA	Door Rail Bottom, Non-locking <800mm	SA
DR8SA	Door Rail Bottom, Non-locking 800-899mm	SA
DR9SA	Door Rail Bottom, Non-locking 900-1000mm	SA

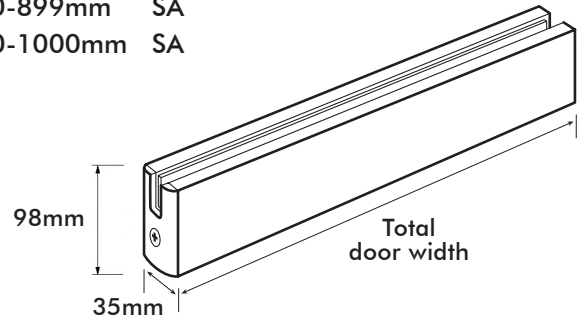
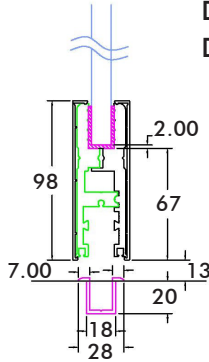

### Note

- Powdercoated covers available. Longer lengths on request

## Top & Bottom Locking Rail

Product Code	Description	Finish
DR4SA	Door Rail Top, Locking <800mm	SA
DR5SA	Door Rail Top, Locking 800-899mm	SA
DR6SA	Door Rail Top, Locking 900-1000mm	SA
DR10SA	Door Rail Bottom, Locking <800mm	SA
DR11SA	Door Rail Bottom, Locking 800-899mm	SA
DR12SA	Door Rail Bottom, Locking 900-1000mm	SA

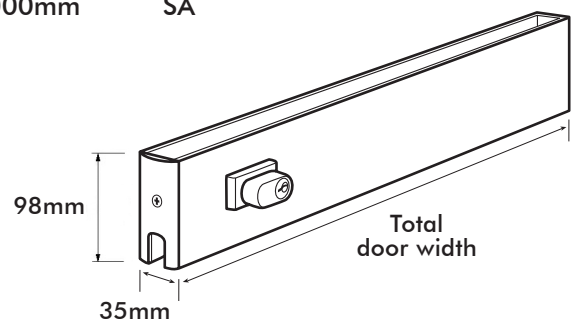
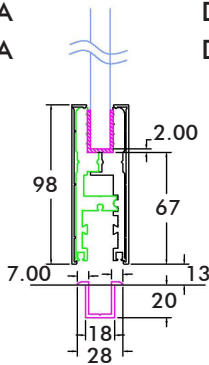

### Note

- Powdercoated covers available. Longer lengths on request

